

Vocal Health for Performers:

Your guide to a strong, clear, easy voice

Keep the larynx hydrated

To vibrate easily and resist injury, the vocal folds need to be kept moist, both internally and externally. Dry air, mouth breathing and smoking all dry the vocal folds externally, while certain drying medications, drinking too much caffeine or alcohol and not drinking enough water dries them internally.

To make sure your vocal folds are well hydrated:

Drink

8 to 10 glasses/day of non-caffeinated, non-alcoholic liquids. Drink more in hot weather and if you are exercising or using your voice a lot. Drink water: it's the easiest and it's what your system needs.

How can you tell if you are drinking enough water?

Follow the dieticians' advice to "pee pale". Check your urine – if it is pale yellow, you are well hydrated; if it is dark yellow and concentrated, reach for the water bottle.

Steam

Breathing humidified air rehydrates the vocal folds from the outside. It can be useful if:

- You have an upper respiratory infection
- Your throat feels tired or sore
- You have been doing a lot of talking or singing. (We automatically breathe through the mouth and that dries out the vocal folds.)
- You are in a dry environment, like an airplane or Saskatchewan.

Steam for 5 to 10 minutes, twice a day.

- Take a hot shower or bath
- Put your face over a bowl of hot water and drape a towel over your head. Be sure it's a comfortable temperature.
- Use a hot water vaporizer (not cold mister)
- Buy your own personal steamer (around \$50– great for traveling to dry places).

Keep the larynx healthy

Anything other than clean, moist air can irritate the vocal folds. While the vocal tract has a housecleaning system that cleanses the mild, common pollutants from the vocal folds, it cannot cope with the two main sources of laryngeal irritation – smoking and reflux.

Smoking

Never, never, never smoke. Anything. Not smoking is the single best thing you can do for your voice. Avoid second-hand smoke as much as you can.

- Smoking dries the larynx and prevents it from becoming rehydrated. Cigarette/marijuana/cigar smoke is hot, polluted air that is drawn directly over the surface of the vocal folds. It dries and irritates. One puff shuts down the larynx's ability to rehydrate itself for about 3 hours.
- Smoking causes the delicate cover of the vocal folds to become swollen and reddened. If the smoking persists these changes become permanent.
- Some of the voice changes that smoking causes include: hoarseness, reduced pitch range, breathiness, vocal fatigue, lack of vocal control.
- Secondhand smoke contains 4000 harmful chemicals
- Smoking kills 1 in 10 adults worldwide. Most throat and mouth cancers are caused by smoking or chewing tobacco.

Reflux

The terms gastro-esophageal reflux disease (GERD) and laryngeal-pharyngeal reflux (LPR) refer to a leakage of stomach acid back up the esophagus onto the vocal folds. This causes redness and irritation, particularly at the backs of the folds. There is widespread agreement that this irritation can cause vocal fold pathologies or aggravate existing ones. It certainly slows healing and there is speculation that the presence of reflux can cause the muscles around the vocal folds to tighten, making it harder to produce the voice.

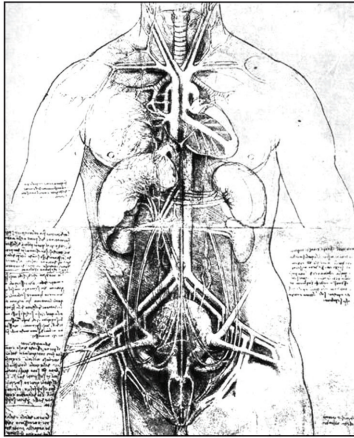

Anatomical study by Leonardo Da Vinci

How do you know if you have reflux?

You need to ask your doctor. He or she will make the diagnosis and give you a plan to manage it. Reflux affects people differently and often those with throat symptoms don't experience heartburn.

Common symptoms of reflux include:

- Gravelly voice, dry, irritated throat - especially first thing in the morning.
- Frequent need to clear the throat or cough.
- Feeling of something stuck in the throat.
- Difficulty in producing the voice - especially at higher pitches.

Managing reflux

Treatment of reflux takes 3 forms: lifestyle changes, dietary changes and medications. Everyone with reflux should follow the first two; medications are taken on consultation with your doctor.

Lifestyle changes:

- Don't eat for 2 to 3 hours before going to bed. This allows the food to pass out of your stomach before you lie down.
- Elevate the head of your bed about 6 inches by putting blocks or old phone books under the bedstead at the head end, so you are sleeping on a bit of a slant. Propping yourself up on extra pillows is not recommended as it can hurt your neck and you may slide down during the night.
- Reducing excess weight around the waist can be helpful.

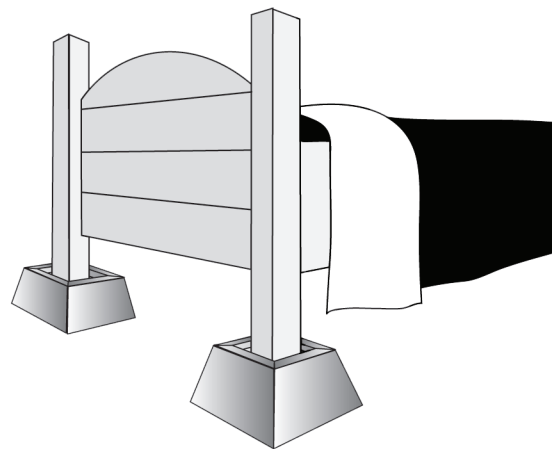

Raise head of bedstead approximately 6 inches.

Diet changes

Some foods aggravate reflux and many people can control their symptoms simply by avoiding or reducing their intake of the following:

- Coffee and other drinks/foods containing caffeine.
- Alcohol.
- High fat foods such as chocolate and fried foods.
- Spicy foods.
- Citrus fruits and their juices, including grapefruit, oranges, lemons, tomatoes.

Medications

There is a wide range of medicines used to treat reflux. They range from over-the-counter antacids to prescription drugs that virtually eliminate all acid production in the stomach. It is best to discuss the use of medication with your doctor. Typically, if anti-reflux drugs are prescribed, they are taken for 1 to 3 months and your progress is reviewed again at the end of that time. That length of time may allow the irritation in the throat to settle down sufficiently for you to then control reflux symptoms with just diet and lifestyle changes.

Keep the larynx harm-free

Avoid phonotrauma

Some things are just plain bad for the voice. Screaming over the band in a bar or yelling advice to a referee at a hockey game can cause trauma to the vocal folds and are not good for anyone. A single, strong scream can be enough to damage the vocal fold tissue in a way that can be hard to fix later. So, unless danger is involved, out and out screaming is out.

Learn good vocal techniques

There are places and times where you need a loud, strong voice and vocal training is designed to help you produce one. When you use good vocal techniques you get a loud voice that lasts well and doesn't hurt your throat. Good technique helps you get maximum mileage from your voice.

However ...

Amplification

There are some situations when even the best technique won't overcome background noise, poor acoustics or sheer volume/amount of voice use required. The human voice, even the best human voice, sometimes needs a little support through amplification. Consider amplification if:

- You are teaching or singing for long hours.
- You are using your voice in poor acoustical environments like out of doors or a large gym.
- You are speaking/singing over a lot of background noise.

When using an amplification system make sure you can hear yourself well, either through your own monitor or the system itself. This is especially important for performers who are in highly amplified situations. There is an almost irresistible urge to push your voice when you can't hear your voice properly.

Earplugs

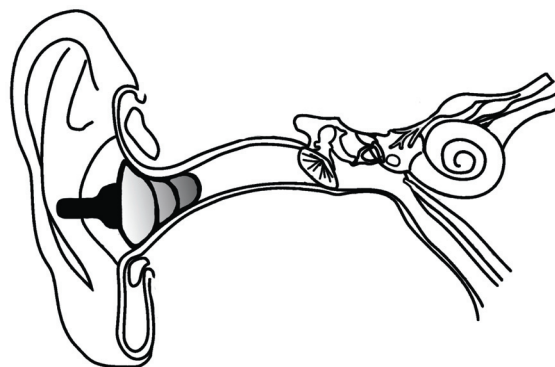

Use earplugs to protect your voice? Absolutely.

When you are speaking or singing around noise, there is a strong urge to push your voice so you can hear yourself. Pushing the voice is always fatiguing and can be damaging, so it is something you never want to do. Using earplugs allows you to better hear your own voice so don't feel the same need to push over the background noise. It is a simple but amazingly effective thing to do.

Not all earplugs are created equal so you have some choice, depending on what you need them to do and how much money you have to spend.

1. Drugstore variety

These earplugs are cheap, easy to find and good for noisy speaking situations like bars and restaurants. You put the earplug in one ear. As you hear your own voice better, you won't shout over the noise - simple but remarkably effective.

However these earplugs were designed to protect your hearing, not to help you hear through noise. They cut out a lot of the high frequencies and distort what you hear. If you are performing or listening to music, you need special earplugs that let you hear clearly while reducing the amount of noise that reaches your ears.

2. Re-usable musicians' earplugs

Musicians' earplugs are specifically designed to allow you to hear well in noisy places. Because they filter out all pitches equally, you simply hear a quieter version of what is happening. They don't distort the sound so they can be used when performing or talking in loud situations – restaurants, kitchens, construction, etc. They also filter out less noise than their drugstore counterparts; you can actually hear better with them than without them.

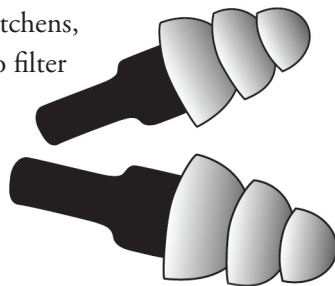

The cheapest way to protect your hearing and your voice from the effects of loud noise is to buy re-usable musicians' earplugs. These reduce the sound level reaching your ears by a moderate amount but still allow you to hear what's going on. And they don't distort the way drugstore earplugs do. They are inexpensive, usually less than \$20, and will last for months with regular use. For most situations, we recommend earplugs with a noise reduction ratio of 12dB. For drummers, or those wanting more noise reduction, get a NRR (noise reduction ratio) of 16 dB.

Purchase options:

Re-usable earplugs can be purchased from a store that sells musical equipment or online at www.earplugstore.com (search ER-20).

Actsafes also carries ER-20 earplugs at a cost of \$10 a pair. Contact us at 604.733.4682 for purchasing information.

3. Custom-fitted musicians' earplugs

These are obtained from an audiologist, who makes an impression of your ear canals and, from that, creates plugs that will fit exactly. They are available with different kinds of filters that will block varying degrees of sound, depending on your needs. They are generally more comfortable than "over-the-counter" earplugs and look professional. The downside is that they are more expensive, roughly \$200 - \$250, but will last indefinitely and are a better option for people who frequently sing highly amplified music.

4. In-ear monitors

An in-ear monitoring system is the most sophisticated way to reduce stage noise and provide good acoustic feedback. The earplugs protect your hearing while carrying your band's sound directly to your ears.

There is a wide range of in-ear monitoring systems at varying prices; check on-line or at a music equipment store.

Dr. Katherine Verdolini is associate professor of communication science and disorders in the School of Health and Rehabilitation Science at the University of Pittsburgh.

Shelagh Davies is a Registered Speech-Language Pathologist with 20 years experience in working with the voice and its disorders. She is in private practice in Vancouver, BC. Visit her online at www.shelaghdavies.com